



## GAS HEATED "BAIN MARIE" MINIDAIRY MBG-100 MBG-200 MBG-300 MBG-400 MBG-500 MBG-650

With these mini-dairies is possible to pasteurize milk and produce cheeses and yoghurt.

### Description:

The basin is made of stainless steel. Heating is achieved by an atmospheric gas burner placed under the bottom double wall. Cooling is achieved by running water going thru side walls. Cooling water may be tap water or coming from chilled water generator.

A insulated external side wall is present for operator protection purpose.



### Features:

- Computer with 4 programs for the driving of thermal processes in manual or automatic mode. Allows the automatic execution of cycles of heating, cooling, pauses and maintenance, programmable by the user.
- Fixed speed electric agitator (22 rpm).
- Discharge flapper valve
- Stainless steel lid composed by two half covers
- Atmospheric Gas Burner
- Cooling water electrovalve
- Gas electrovalve
- Chimney for burner fumes.

### Options:

MBG-xxx/1: CHEESE KIT (Planetarium + Double Harp)

MBG-xxx/2: TEMPERATURE CHART RECORDER (circular type on 24 hours disk, inserted in the command board).



MBG-xxx/3: VARIABLE SPEED AGITATOR from 2 to 44 rpm through electronic inverter. The regulation takes place for means of a pot placed on the command board.

MBG-xxx/4: SUPPORT FRAME that brings the height of the discharge to 1 mt allowing to directly discharge on the tables.

MBG-xxx/5: PLATFORM + STAIRS to access the Minidairy from top (discharge at 1 mt allowing to directly discharge on tables).

**Technical data:**

Power supply: 230V, single phase - 0,3 KW

Model	Max capacity. (Lt)	Min capacity. (Lt)	Thermic Power kcal/h (KW)
<b>MBG-100</b>	100	20	8.500 (10)
<b>MBG-200</b>	200	40	10.000 - 17.000 (12 - 20)
<b>MBG-300</b>	300	60	10.000 - 17.000 (12 - 20)
<b>MBG-400</b>	400	80	17.000 - 34.000 (20 - 40)
<b>MBG-500</b>	500	100	17.000 - 34.000 (20 - 40)
<b>MBG-650</b>	650	130	17.000 - 34.000 (20 - 40)

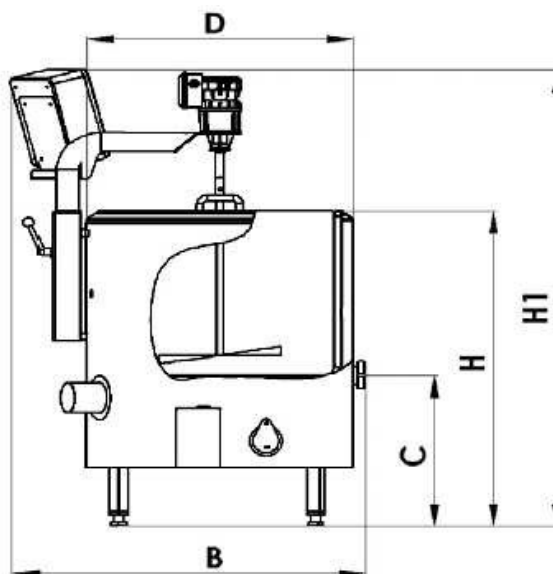

**Dimension e Weights:**

Model	Ø D est. mm	C mm	B mm	H mm	H1 mm	Weight kg
<b>MBG-100</b>	850	400	1050	1000	1350	150
<b>MBG-200</b>	850	400	1050	1000	1450	195
<b>MBG-300</b>	1000	400	1250	1000	1459	250
<b>MBG-400</b>	1120	350	1350	1000	1450	290
<b>MBG-500</b>	1120	350	1350	1100	1600	315
<b>MBG-650</b>	1320	350	1600	1070	1550	365

*The Company reserves the right to modify the technical data and characteristics at any time without notice*